

RTA R407C

“ROOF-TOP” chillers and heat pumps
With capacities from 8.4 to 47.7 kW



Aermec adheres to the EUROVENT Certification Programme. The products concerned appear in the EUROVENT Certified Products Guide.



- Available in 9 different sizes
- All versions are supplied for use with **R407C**
- Heat pump (H) versions
- Peraluman metal cabinet
- Direct expansion coils with condensate drain tray
- Scroll compressor
- Variable speed centrifugal fans in the treatment unit, axial flow fans in the condensation unit
- Front, side and downward air discharge of the treatment unit
- G4 class pleated synthetic filter
- Microprocessor control
- Main switch with door handle
- Compressor thermal-magnetic circuit breaker

Accessories:

AVX: Spring anti-vibration mounts.
BRE: Electric heating coils with 2 or 3 stages.
BRT: 2- or 3-row water heating coil with modulating three-way valve already installed.
BS: Coils for corrosive environments.
D: Desuperheater only for versions 100 - 150 - 200.
DCPR: Low temperature device for operation of outdoor units at ambient temperatures from less than 20 °C down to - 10 °C.
FCH - FCT: Enthalpy or temperature free cooling.
GP: Safety grille: protects external coils from accidental impact and hail damage.
PAA: For fire alarm.
PR: Remote control panel with ON/OFF, operating mode selection (cooling / heating) and general alarm indication.

PRF: For smoke detector.

PUC: For ON-OFF contact humidification.

Roof curb: subframe made of hot galvanized steel plate.

SM: Mixture chamber with servo-control and rain cover included.

SM3: Mixture chamber with three dampers with servo-control, rain cover and intake fan included.

SQA: Air quality sensor (VOC) depending on the overcrowding only for versions 100 - 150 - 200.

SSV: Supervision system.

TP: High and low pressure switches with pressure readings monitored on machine display.

TV: Diversified supply voltage.

VT: Anti-vibration mounts; set of four mounts to install in locations under the baseplate of floor-standing units to attenuate the transmission of vibration generated by the compressor.

■ = Cooling R407C - ■ = Heating R407C

Mod.		025	030	040	050	080	090	100	150	200
Cooling capacity	kW	8,4	9,8	11,6	14,8	20,1	22,0	29,2	35,1	47,7
Total input power	kW	2,95	3,56	4,75	5,83	7,2	8,3	10,5	12,8	15,8
Total input current	A	5,7	6,4	8,3	10,0	13,5	15,5	18,2	21,8	27,6
Cooling capacity (RTA H)	kW	7,9	9,2	11,0	14,0	18,8	20,6	27,4	33,0	44,5
Total input power (RTA H)	kW	3,1	3,6	4,7	5,8	7,3	8,0	10,5	12,9	15,8
Total input current (RTA H)	A	5,5	6,3	8,3	10,0	13,0	15,4	18,3	21,8	27,3
Heating capacity	kW	7,4	8,7	10,9	13,9	17,5	19,5	25,6	31,2	41,6
Total input power	kW	2,8	3,3	4,3	5,5	6,5	7,6	9,4	11,6	14,3
Total input current	A	5,1	5,9	7,8	9,2	12,3	15,5	16,5	19,9	25,4
Compressors	no.	1	1	1	1	1	1	1	1	1
Input current	A	8	10	12	14,5	18,3	20	27	33	39
Peak current	A	45	51	55	71	106	104	140	145	208

Treatment Unit

Fans	n°	1	1	1	1	2	2	2	2	2
Nominal air flow rate	m³/h	1500	1900	2400	2900	4000	4500	6000	8000	9000
Motor power	kW	0,42	0,42	0,6	0,6	1,1	1,5	1,5	2,2	3,0
Effective pressure ⁽¹⁾	Pa	215	160	250	215	290	320	280	280	360
Effective pressure ⁽¹⁾ (RTA H)	Pa	215	160	250	215	270	250	300	300	300

Condensation Unit

Fans	n°	1	1	1	1	1	1	4	4	4
Fan speed	rpm	870	870	870	870	870	870	870	870	870
Nominal air flow rate	m³/h	3.500	3.500	4.800	6.200	8.000	8.000	14.000	14.000	14.000
Motor power	kW	0,15	0,15	0,25	0,25	0,52	0,52	0,6	0,6	0,6

⁽¹⁾ = Useful head available for the system in the standard configuration

Power supply = 400 V - 3 - 50Hz.

Performance values refer to the following conditions:

Cooling:

room air temperature 27 °C HR 50%;
ambient air temperature 35 °C.

Heating:

room air temperature 20 °C;
ambient air temperature 7 °C D.B., 6 °C W.B.;

Dimensions (mm)

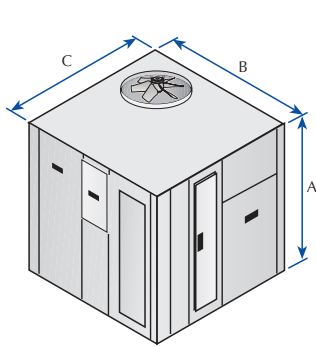

025 - 050

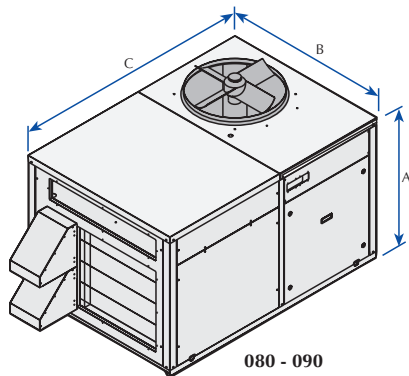

080 - 090

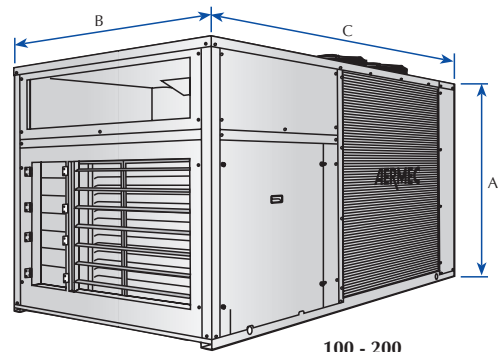

100 - 200

		025	030	040	050	080	090	100	150	200
Height	A	1038	1038	1038	1038	1188	1188	1500	1500	1500
Width	B	1155	1155	1155	1155	1240	1240	1500	1500	1500
Depth	C	1175	1175	1175	1175	1800	1800	2600	2600	2600
Weight (kg)	RTA	235	250	270	285	435	450	650	675	735
	RTA H	245	260	280	300	455	470	690	710	770

The technical data in this document are not binding. Aermec S.p.A. reserves the right to make whatever modifications it deems necessary to improve the product at any time.

Aermec S.p.A.

Via Roma, 44 - 37040 Bevilacqua (VR) - Italy
Tel. +39 04 42 63 31 11 - Telefax +39 044 29 35 66
www.aermec.com